

WTC801SPI

**WTC801SPI Touch sensitive eight keys + roller chip
Specification (V1. 1)**

1. Brief introduction of the product

1.1. Overview

WTC801SPI is a Touch sensitive IC designed for touch-button of replacing mechanical type and mechanical knob. It can achieve waterproof, dustproof, seal isolation, with solid and artistic operation interface.

A WTC801SPI can implement 8 keys and 1 roller (Slide bar).

1.2 Technical Parameters

Operating voltage: $2.4V < V_{cc} < 5.5V$

Output voltage range: $GND < V_{out} < V_{cc}$

Sensing thickness (insulating medium): 0-10mm, Maximum 10 mm

Response time of effective touch: Less than 150ms

Operating temperature: $-40^{\circ}C \text{---} +85^{\circ}C$

Storage temperature: $-50^{\circ}C \text{---} +125^{\circ}C$

State current: 18uA (3V power supply)

Dynamic current: 1.2 mA (3V power supply)

Wake-up mode: touch sensitive key to awaken

2. Main application

The touch sensitive control of electrical equipment, physical quantity regulation, such as the acoustic volume, and the brightness of luminaires, lighting color, power temperature control of household appliances etc..

3. Definitions of WTC801SPI Pins

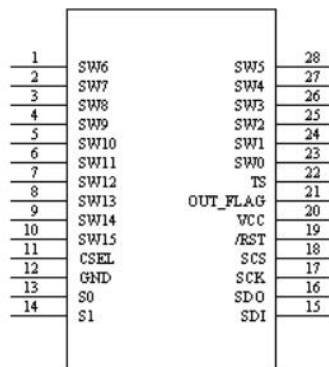

Figure 1: Pin Diagram of WTC801SPI

**WTC801SPI**

Table 1: Definitions of WTC801SPI Pins

Pin No.	Pin Name	Usage	Function Description
1	SW6	I	Capacitive sensor (key sense element) interface 6
2	SW7	I	Capacitive sensor (key sense element) interface 7
3	SW8	I	Capacitive sensor (pulley sense element) interface 8
4	SW9	I	Capacitive sensor (pulley sense element) interface 9
5	SW10	I	Capacitive sensor (pulley sense element) interface 10
6	SW11	I	Capacitive sensor (pulley sense element) interface 11
7	SW12	I	Capacitive sensor (pulley sense element) interface 12
8	SW13	I	Capacitive sensor (pulley sense element) interface 13
9	SW14	I	Capacitive sensor (pulley sense element) interface 14
10	SW15	I	Capacitive sensor (pulley sense element) interface 15
11	CSEL	I	Sensitivity adjustable capacitor interface
12	GND	I	Power ground
13	S0	O	The internal test leg Usually needs to suspend the S0
14	S1	O	The internal test leg usually needs to suspend the S1
15	SDI	I	Data input line of the chip SPI interface is input the sensitivity adjustment data
16	SDO	I	The data output line of the chip SPI interface is output the key and slider data
17	SCK	I	The clock input line of the Chip SPI interface
18	SCS	I	The chip selection enabled line of Chip SPI interface
19	/RST	I	Chip reset pin
20	VCC	I	positive power supply output
21	OUT FLAG	O	Key status indicator has the output low level signal when pressing the key or slide bar, and the output high level signal when the finger leaves the key or slide bar. The initial of the electrifying is the high level output
22	TS	O	The internal test leg needs to suspend the TS
23	SW0	I	Capacitive sensor (key sense element) interface 0
24	SW1	I	Capacitive sensor (key sense element) interface 1
25	SW2	I	Capacitive sensor (key sense element) interface 2
26	SW3	I	Capacitive sensor (key sense element) interface 3
27	SW4	I	Capacitive sensor (key sense element) interface 4
28	SW5	I	Capacitive sensor (key sense element) interface 5

Chip Application Schematic Diagram

WTC801SPI

RP1 and RP2 are the match resistance group. Please try to place them close to the IC

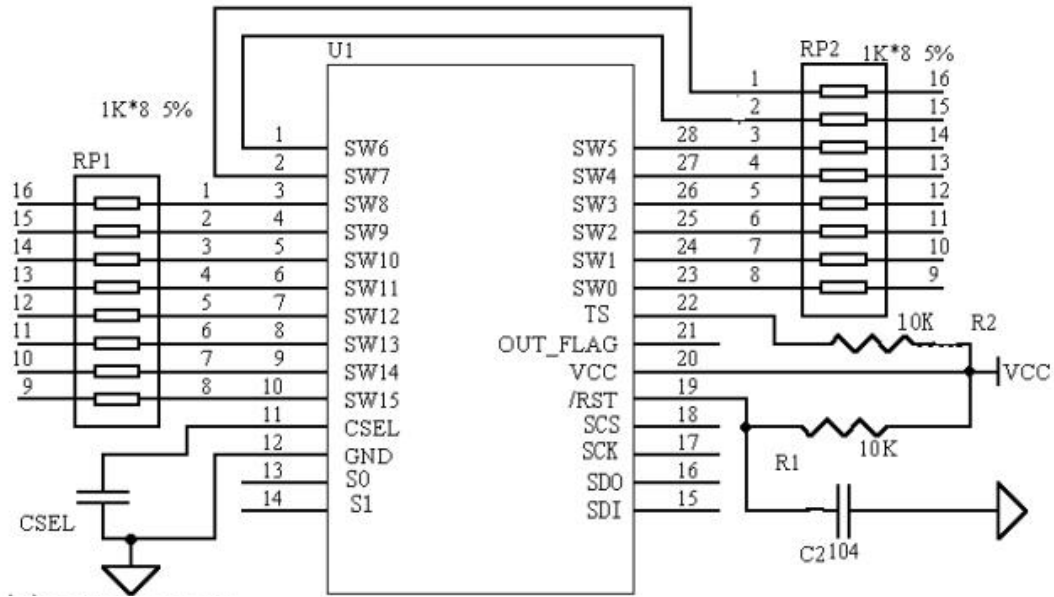

10 % polyester capacitance 0.0047UF-0.022UF

4. The sleep and awakening of the chip

When the touch pulley or touch key is not touched, after 15 ~ 20 seconds, the chip will automatically enter the power saving sleeping mode to save the working current. At this time, the power consumption of the chips is only 18 ~ 20uA under 3V condition. The touch pulley is no longer working in the sleeping mode.

The chip can be awakened by touching any keystroke sensor under the sleeping mode. The working current of the chip after being awakened is about 1.2 mA under 3V condition. After entering sleeping, the touch pulley cannot wake the chip.

5. Output Display

When the effective touch on the sensor key or pulley is detected, the OUT_ FL WTC801SPI in 150ms will output a low level signal, and the low level will remain and will become high level until the finger has left the key or the pulley.

6. The SPI interface of WTC801SPI

6.1 SPI sequence diagram

The SPI time sequence diagram is shown in figure 4

WTC801SPI

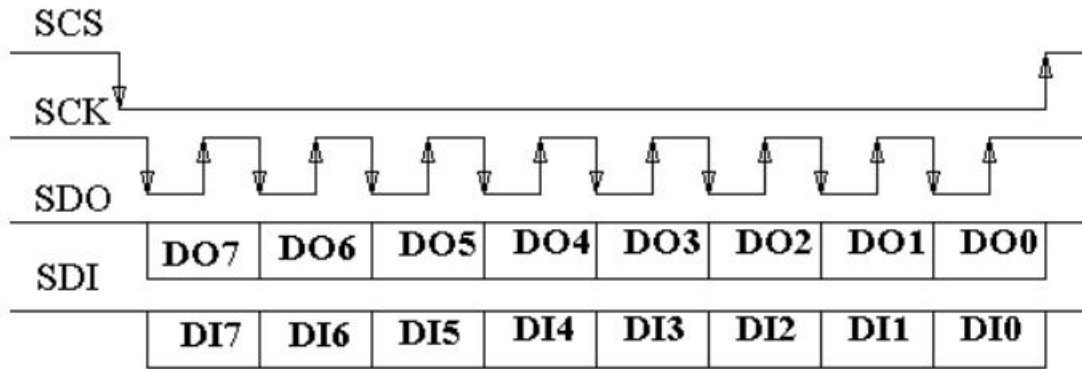

Figure 4: Sequence diagram of the SPI interface of WTC801SPI

6.2. SPI port work status of WTC801SPI

The working subordinate machine state of SPI port of WTC801SPI

6.3. PI signal line function

SCS is the enable signal of chip selection of SPI port, is set by the user MCU. The SPI port does not work when SCS = 1. SPI port function is opened when SCS = 0.

SCK is the clock signal of SPI port, generated by user MCU. The initial electrical level should be high.

SDO is the SPI data output signal of WTC801SPI, and the user MCU reads the status of SDO to obtain key data.

SDI is the SPI data input signal of WTC801SPI, and the user MCU can set the sensitivity of the touch key with software by setting SDI. Please be sure to set the SDI to be high level when not in use.

6.4. Data transmission rules of SPI

The data of SPI is transmitted beginning from the highest level.

6.5. SDI signal processing

If you do not use software to set touch sensitivity through setting SDI, please connect SDI to VCC.

If SDI is needed to be used, SDI must be set to be high level before reading the SDO operation.

Otherwise, the touch sensitivity may be wrong set to be 0.

7. Notices for using the SPI interface

7.1. The two read intervals are not less than 4ms

If the SPI interface of WTC801SPI is continuous read-write, it will cause the instability of the device working. The time of reading and writing twice should be more than 4ms.



WTC801SPI

7.2. SCS and SDI, SDO are not allowed to be suspended at any time

If there is no master control MCU of the SPI interface on the touchpad, then the pulling resistance must be added on the SCS and SDI and SDO of WTC801SPI, to ensure that the chip can steadily operate. SCS and SDI, SDO cannot be suspended at any time.

7.3. SDI can be fixed to connect VCC

If the sensitivity of WTC801SPI is not set by using the software, the pulling resistance must be added to SDI Or SDI must directly connect to fix the VCC to set the high.

7.4. SCS is not allowed to be fixed grounding

SCS is not allowed to be fixed grounding

The SPI data format of WTC801SPI

From the SDO output (the key or slide bar data read by the host)

Bit7	When it is 1, it indicates the key value data of the touch key (the k valid value of the key value data is 80H ~ 87H). When it is 0, it indicates the position data of the touch roller (the valid value of the location data is 0~7FH).
Bit6	The 6th place of the Key value data or location data (key value or location data is determined by Bit7)
Bit5	The 5th place of the Key value data or location data (key value or location data is determined by Bit7)
Bit4	The 4th place of the Key value data or location data (key value or location data is determined by Bit7)
Bit3	The 3rd place of the Key value data or location data (key value or location data is determined by Bit7)
Bit2	The 2nd place of the Key value data or location data (key value or location data is determined by Bit7)
Bit1	The 1st place of the Key value data or location data (key value or location data is determined by Bit7)
Bit0	The 0 place of the Key value data or location data (key value or location data is determined by Bit7)

From the SDI input (the Sensitivity adjustment data write by the host)

Bit7	It must be 0. If it is 1, the transmission this time is not valid
Bit6	It must be 0. If it is 1, the transmission this time is not valid
Bit5	When it is 1, it indicates the data set is the sensitivity of the touch key. When it is 0., it indicates that data set this time is the sensitivity of the touch pulley
Bit4	The 4th position of the key sensitivity or pulley sensitivity (the data of key or pulley is determined by Bit5).
Bit3	The 3rd position of the key sensitivity or pulley sensitivity (the data of key or pulley is determined by Bit5).
Bit2	The 2nd position of the key sensitivity or pulley sensitivity (the data of key or pulley is determined by Bit5).
Bit1	The 1st position of the key sensitivity or pulley sensitivity (the data of key or pulley is determined by Bit5).
Bit0	The 0 position of the key sensitivity or pulley sensitivity (the data of key or pulley is determined by Bit5).

For the use of the chip SPI interface, the user can also directly refer to the DEMO program of the final appendix of the specification, which will be more intuitive and simple.



WTC801SPI

8. Sensitivity Setting

8.1 Sensitivity adjustment mode

The sensitivity setting of WTC801SPI enables the user to use isolated media of various thicknesses to implement reliable and flexible touch function.

The sensitivity of WTC801SPI is set by using the double setting of soft and hardware. The user can be fix the SDI to connect the high level, so that it does not use the sensitivity adjustment function of software, just adjusts the Csel to realize the sensitivity setting, so that the master control MCU can save a I/O port line, and also reduce the software space of the master MCU.

8.2 The material of Benchmark capacitance CSEL, , value range precision requirements

1. Selection of Suitable Capacitor CSEL

The user can select the appropriate capacitance Csel according to the own use case. The larger the separation medium is, the larger the Csel capacity is. It is generally recommended to choose the appropriate capacitance between 0.0047 UF and 0.022 UF from large to small. It is recommends that it is best to use the A 5 % precision polyester capacitor with a small temperature coefficient for Csel. 10 percent accuracy of polyester capacitance can also be used. If needing use of patch capacitors, 10% or higher precision NPO material or X7R capacitance needs to be used.

2: Notices for the sensitivity of the touch key sensor set by the software

The master control MCU will reset every time after the sensitivity is set, and the reset will take 80ms. In the 80ms time when the touch chip is reset, regardless of whether it is reading or writing, it will not get the correct result. Therefore, the master control MCU must wait for more than 80ms after sitting the sensitivity of master control MCU is completed, then the read-write can be made to the serial interface of WTC801SPI.

It is recommended that the master control MCU should not frequently set the sensitivity of touch chip in the program. Just setting it once when the program is initialized.

The sensitivity of touch key is divided into 32 grades, and the corresponding series data is 0 ~31. The higher the series is, the higher the sensitivity of the touch key is. But if the set series data is more than 31, this set will be invalid. After the invalid set is transmitted to end bit, the touch chip won't to reset and won't adjust internal parameters, can still use the previous sensitivity parameters.

After the touch chip is electrified for the first time, the inside setting of the sensitivity is automatically set to be the level 31. The user can adjust the sensitivity by not using the not use the software, to use the chip's default parameters directly.

8.3. The effect of the area and size of the sense element on sensitivity

Increasing the area of sense element can improve the penetration ability of touch sensing.

9. WTC801SPI used capacitive sensors (sense element)

9.1. The material and shape of the capacitive sensors

The capacitive sensors can be any type of conductor, but certain flat surface should be ensured. It is recommended to use a round metal sheet or other conductor with a diameter greater than 12mm. The commonly used sense element are copper foil, spring, thin film line and ITO glass, etc. on the PCB plate. As shown in Figure 9.

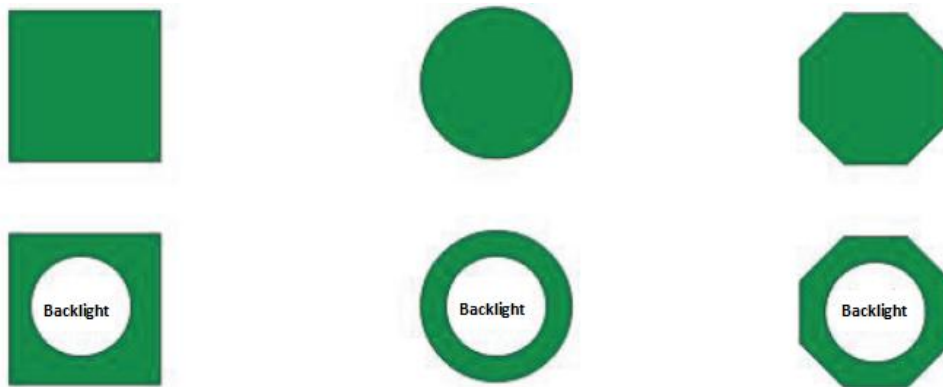

The key sense element can be solid or hollow rectangle, circle or polygon.

Figure 9: PCB Copper Foil sense element

9.2. The area of the key sense element

The area of each sense element should be kept as same as possible to ensure the same sensitivity.

9.3 The fitting between the sense element and the panel

Capacitive sensors shall be close to the glass and other insulating panels, or the elastic bonding is used for it. The common bonding methods are:

- A Use the sensor element with spring
- B Use cylindrical conductive rubber to conduct elastic connection
- C Paste the sense element onto the panel with imported super double-sided glue, and the double-sided glue layer cannot be too thick. As shown in Figure 10.



Figure 10: Spring sense element

9.4. Eliminate the joint gap

The contact surfaces of the sense element and the binding face of the insulation panel must be flat, ensuring that there is close fitting of no clearance between them.

9.5. The equilibrium of the key and roller (Slide bar) sensitivity

If the sensitivity of the sensor key and the inductive pulley is not consistent, the resistance of the matched resistance can be adjusted through the adjustment of the impedance channel. The greater the matching resistance is, the lower the sensitivity of the corresponding induction channel is. But the value of the matching resistance is not smaller than 1K. The value of the matching resistance of the tandem connection on the pulley induction channel must be consistent.

10. Capacitive sensors used for the pulley or slide bar and layout suggestions

- The double-sided PCB board is used for the design
- Capacitive sensor (sense element): use the capacitance sensor (key sense element) made of copper foil on PCB and the capacitance sensor of roller (Slide bar). The area of each capacitive sensor should be kept as the same as possible, to ensure the same sensitivity. Capacitive sensor should be placed in the TOP layer.
- The touch chip is placed in the proper position of the BOTTOM layer.
- The connection line between the capacitive sensor and the pin of the touch chip all goes to the BOTTOM layer
- The connection line between the capacitance sensor and the pin of the touch chip is as short and thin as possible (5 ~ 8mil).
- Do not lay copper and other circuits on the back and surrounding 0.2mm, to ensure that the sensor having good sensitivity and to avoid false triggering.
- Touch roller (Slide bar)

The shape and size of the touch sensitive slide bar is shown in FIG. 4. The size of the capacitor sensor can be scaled appropriately according to the design requirements of the panel, and the slide bar can be designed as a curve.

Touch pulley

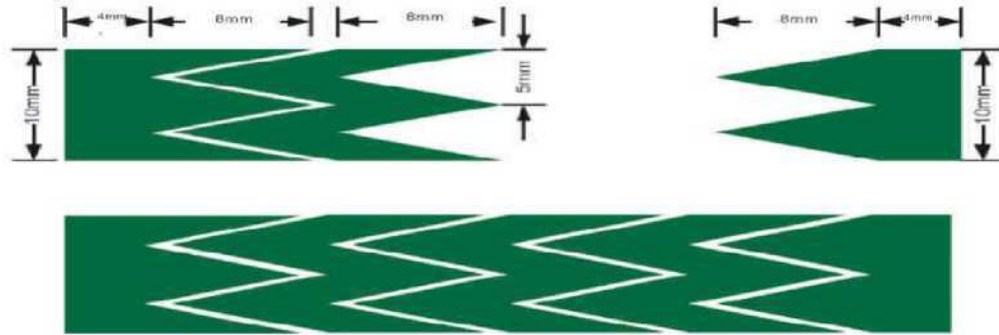

Figure 11: Geometry and dimension of touch slide bar

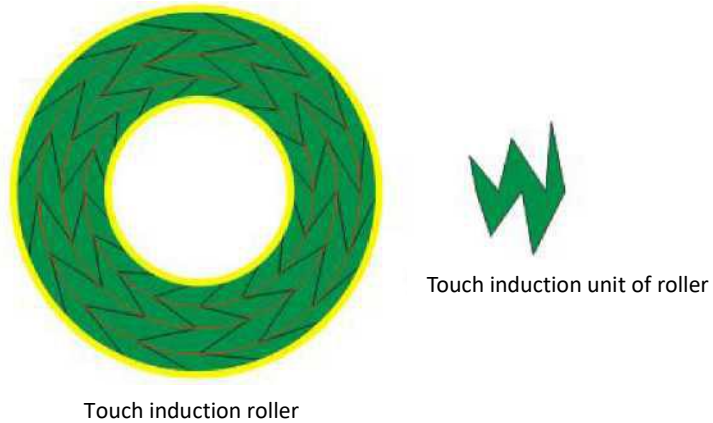

Figure 12: Geometry and dimensions of the Touch roller

The shape of the induction unit of the touch-sensitive roller is as shown in figure 5. The clearance between the induction units is 0.1 -0.2 mm, and the inside and outside diameter of the roller is 18mm and 36m respectively. The size of the roller can be appropriately scaled in proportion according to the panel design requirements.

The arrangement order of the touch induction roller induction unit clockwise starting from left is: SW13,SW10.SW15,SW12,SW9,SW14,SW11,SW8,SW15.SW14,SW13,SW12,SW11,SW10, SW9,SW8 (For the specific details, please refer to the application schematic diagram and the PCB diagram of the DEMO board provided by us)

WTC801SPI

11. Processing of Vacant Sensor Channel

The WTC801SPI requires that at least three touch keys must be used, and when the WTC801SPI is used in the situations of less than 8 keys, SW7 ~SW0 will have empty unused sensor input channel.

The empty input channel can be simply suspended in midair, and any pull-up or pull-down resistance cannot be added in the empty input channel.

If the user must use three or less sensitive keys, please be sure to contact us for the corresponding technical support.

12. Package Dimension Drawing of WTC801SPI

Symbol	Dimensions in mil		
	Min.	Nom.	Max.
A	228	—	244
B	150	—	157
C	8	—	12
C'	386	—	394
D	54	—	60
E	—	25	—
F	4	—	10
G	22	—	28
H	7	—	10
α	0°	—	8°

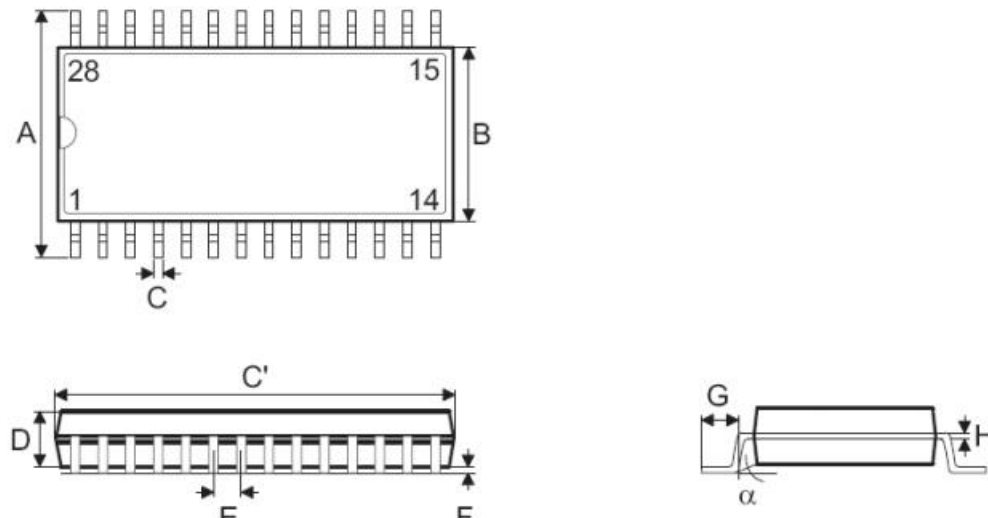

Figure: Package Dimension Drawing of WTC801SPI



WTC801SPI

DEMO program read and written by SPI

```
//-----  
//-----  
void main(void)  
{  
    SCS = 1;    // Close the SPI port to enable  
    SCK = 1; //SCK The initial electrical level is high  
    SDI = 1; //SDI SDI is set to be high level  
    set_Subtle_SPI(10 | 0x20);    //Delay_loop(5ms);  
    Set the key sensitivity to 10 level delay_loop(5ms);  
    delay_loop(5ms);    // 5MS Delayed  
    set_Subtle_SPI(10); // set the slider sensitivity to be the level 10  
    delay_loop(5ms);    //5MS Delayed  
  
    while(1)  
    {  
        SDI = 1;  
        if(~OutFlag)  
        {  
            delay_loop(5ms);    //Delayed, in the actual program, it can read the SPI every 5MS  
            GetKey = get_key_data();    //Read the key value  
            if (GetKey & 0x80 == 1)  
            {  
                //bit7 The bit7 which the read is 1 is the key data of the key  
                GetKey &= 0x7F;    //Set the 7 place of the data to be 0 to get the key value of the key  
            }  
            else  
            {  
                //bit7 is the slider data read by 0  
            }  
        }  
    }  
}
```

//-----

```
uchar get_key_data(void)  
{  
    uchar    KeyData;  
    uchar    i;  
    KeyData = 0;  
    i = 0;    //The initial of counter is 0  
    SDI = 1; //SDI The setting of SD is high to avoid error setting the sensitivity of touch chip  
    SCS = 0; // Open the SPI to enable  
    do  
    {  
        KeyData <<= 1;    //MSB is the number one of data  
        SCK = 0; //SCK Signal falling edge  
        if(SDO == 1) //Read the data of SDO  
        {  
            //SDI is the high level
```



WTC801SPI

```
        KeyData |= 0x01;
    }
    else
    {
        //SDI is the low level
        KeyData &= 0xFE;
    }
    SCK =1;//SCK Signal rising edge
    i++;    // Counter adds 1
}while (i < 8); // Cycle reading 8 times
SCS = 1;    // Close the SPI port to enable
return(KeyData); // Return the read key information
}

//-----
void    set_Subtle_SPI(uchar temp) //Sensitivity setting
{
    uchar i;
    i=0;    //The initial of counter is 0
    SCS = 0;    //Open the SPI port to enable
    do
    {
        if((temp & 0x80) != 0)    //The first place of the transmitted data is MSB

        {
            //The current value of the sensitivity setting value is 1
            SDI = 1;
        }
        else
        {
            //The current value of the sensitivity setting value is 0
            SDI = 0;
        }
        SCK = 0; //The falling edge of SCK signal
        SCK = 1; //The rising edge of SCK signal
        temp <<= 1;    //The first place of the transmitted data is MSB
        i++;//Counter adds 1
    }while (i < 8);    //Circular transmission 8 times
    SCS = 1;    //Close the SPI port to enable
    SDI = 1;    //SDI is set to be high level
}
```